

GRIPPER FOR 80 LB. DISCS,  
ALLOWS PICK AND PLACE  
AT ANY ANGLE

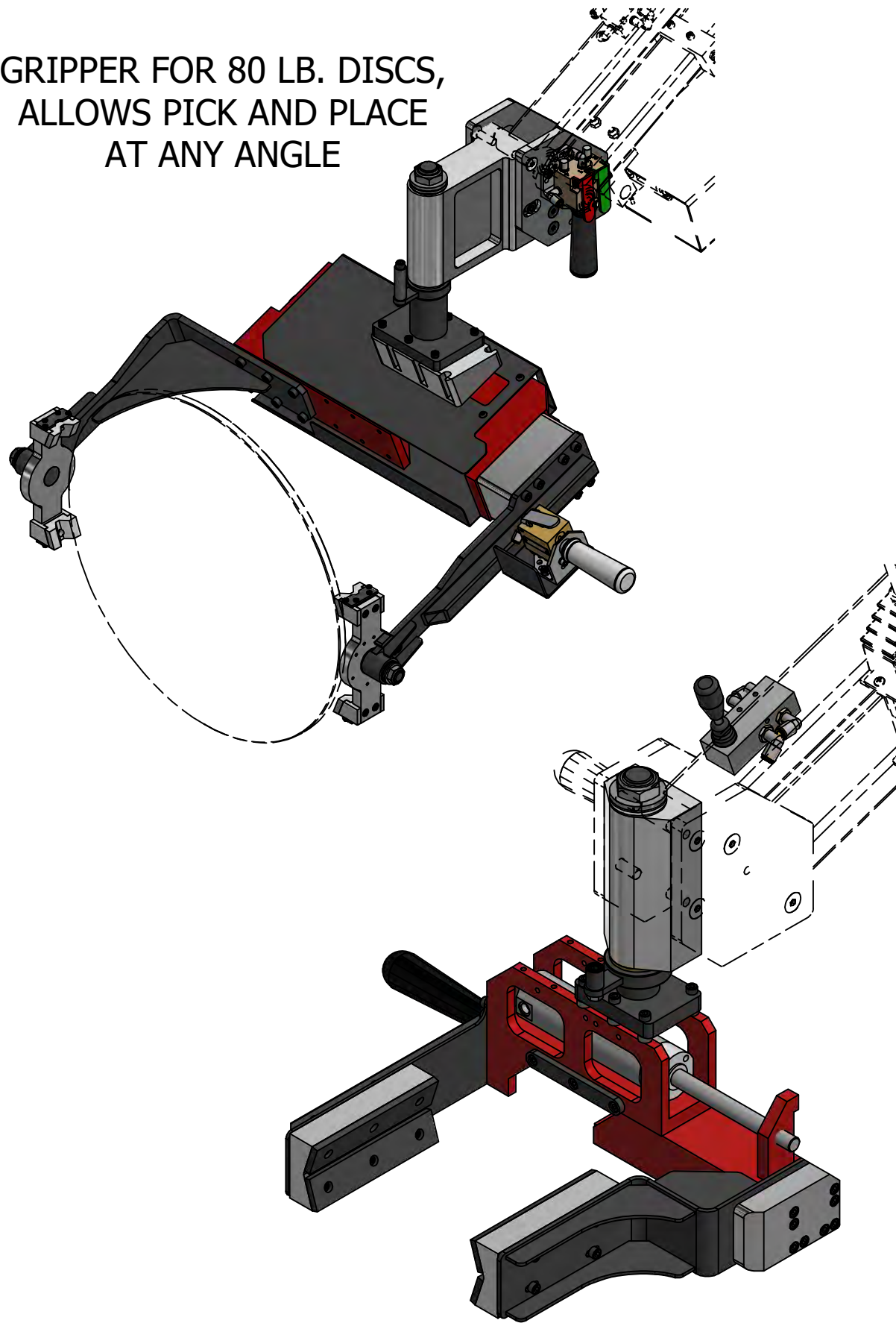

GRIPPER FOR MOTOR  
PICK AND PLACE

GRIPPER FOR ROUND  
AND SQUARE TUBE WITH  
HORIZONTAL AND VERTICAL  
ROTATIONS

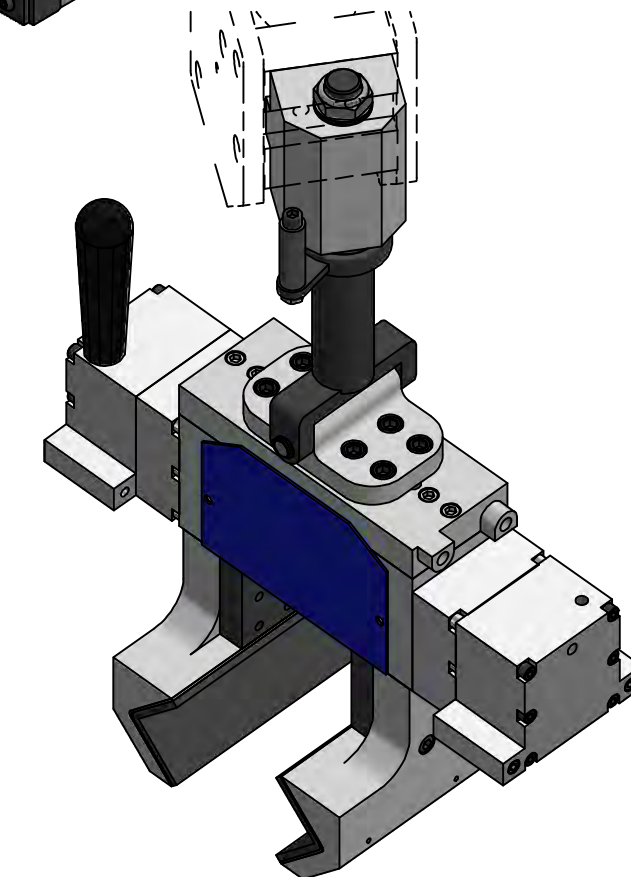
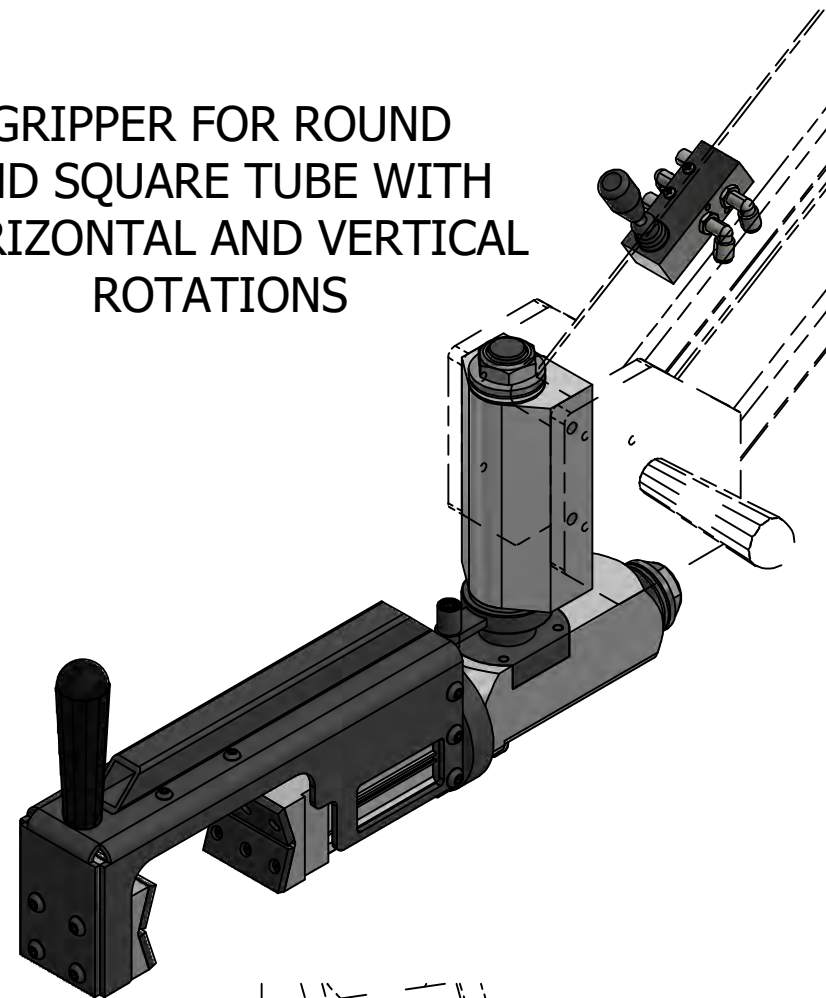

GRIPPER FOR SQUARE TUBE

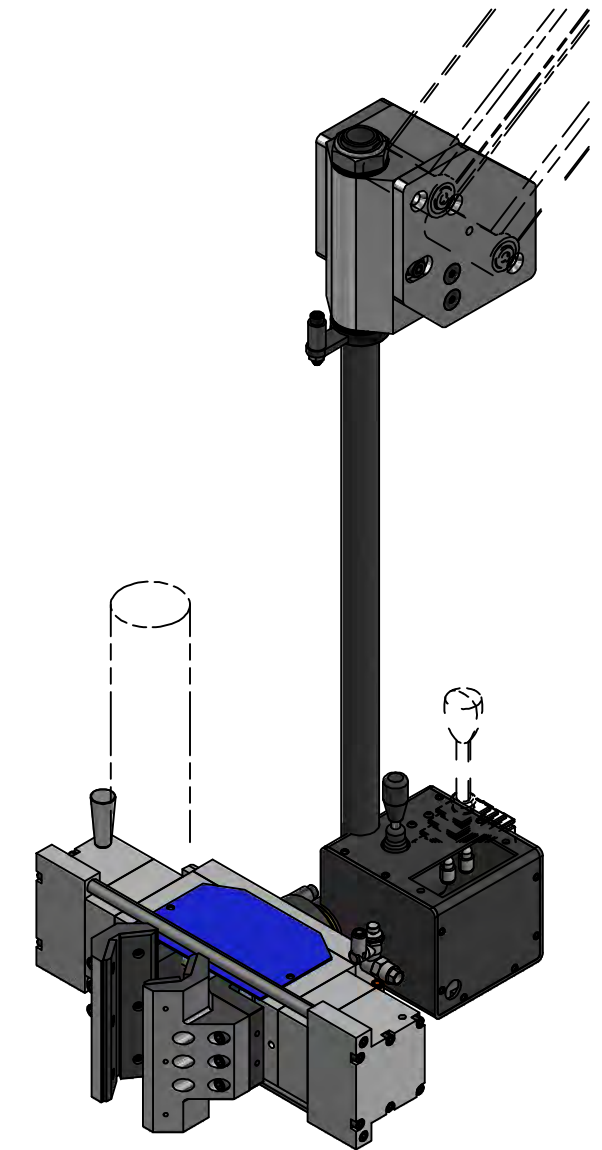

REBAR GRIPPER WITH VERTICAL  
AND HORIZONTAL ROTATIONS

<i>Date:</i> 7/17/2020	<i>Tolerance:</i> DECIMAL: .00.....±.010 .000.....±.005 .0000.....±.0005	<i>Drawn By:</i> Cylar	<i>Option No.:</i> PM
<i>Name:</i> PM CUSTOM END EFFECTORS			
<i>Material Specs:</i>			<i>Sheet:</i> 1 OF 1
<b>Flex</b>  <b>arm</b> Tapping & Assembly Arm Solutions		<i>Part No.:</i> PM	